



Height Adjustment:

With the door in the closed position, remove the top cover cap by applying pressure on the rear surface as shown opposite. The front of the cap should lift, you may need to prise it gently to remove it.

Now viewing the hinge from above, use a 3mm allen key and release the locking cam by turning anti-clockwise. See highlight in Red.

Raise or lower the door by adjusting the height screw. Use a 3mm allen key and turn clockwise to raise the door and anti-clockwise to lower the door.

Once the desired height is achieved return the locking cam to the locked position and replace the cover cap.

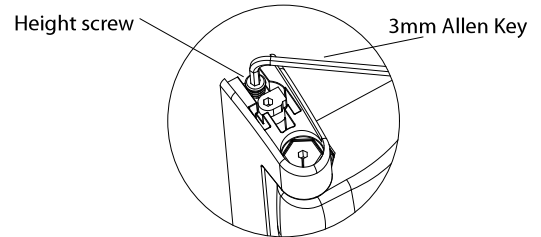
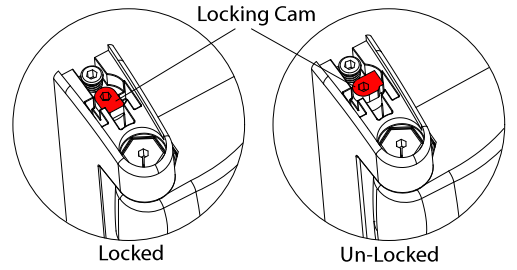
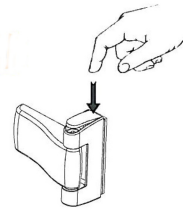

Horizontal Adjustment:

With the door in the open position locate the cover cap screw and remove it using a 3mm Allen Key. Be careful whilst removing as this will release the main cover cap and could potentially drop to the floor.

Using the correct screwdriver slightly release the fixing screws taking pressure off the adjustment bolt. Adjustment can be made using a 4mm Allen Key. Turn the adjustment bolt clockwise to move the door away from the hinge side and towards the lock side. Anti-clockwise to move the door closer to the hinges.

Remember to re-tighten the fixing screws once adjustment has been made and replace the cover cap.

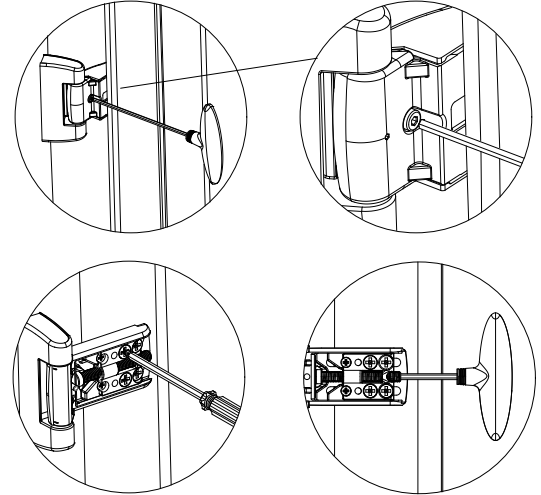

Compression Adjustment:

With the door in the closed position, remove the top cover cap by applying pressure on the rear surface as shown opposite. The front of the cap should lift, you may need to prise it gently to remove it.

Open the door so that you can see the reverse of the hinge. Using a 2mm allen key loosen off the pin security grub screw located at the rear of the hinge, this will allow the compression pin to move freely.

Tap the pin from the underneath, see arrow opposite until the hexagon head of the pin is free to rotate (approx 10mm up). Using a 4mm allen key rotate the pin either clockwise or anti-clockwise to obtain the required compression setting.

Note that the neutral setting should see the small line on the top of the hexagon head facing the 9 o'clock position.

To finish ensure that the 2mm security grub screw on the reverse of the hinge has been re-tightened and then replace the end cover cap.

