

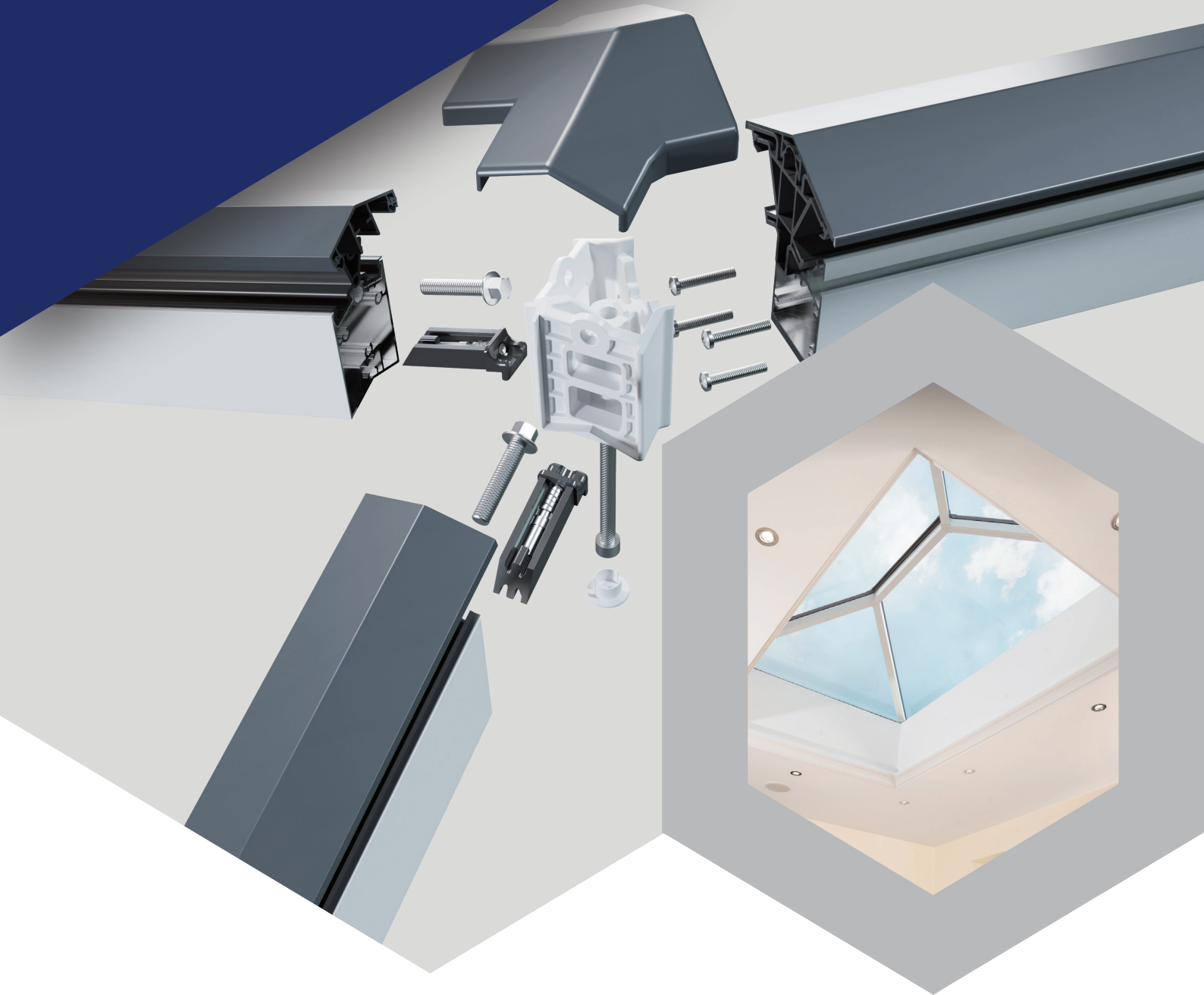

# Installation Guide



**PART L** Compliant ✓

**Tools Required** PZ2 Driver Bit, 13mm socket, 6mm Allen key and T25 T-bar or bit

- Ensure the supporting construction has been completed and that the upstand is square by checking the external diagonal measurements. Clean any debris away from the roof ensuring the weatherproof membrane is clean and free from any defects or damage.

- Check the roof lantern has been delivered in full before the installation begins.

- Unpack the eaves beams and begin to assemble. Apply a fine bead of silicone sealant to the mating faces of the eaves beam to prevent water ingress, see drawing 1.2. Using SM113 corner cleat & SH113 chevron in each corner joint. position the corner cleat in to eaves beam and tighten using a T25 Torx bit, insert the Chevron into the corresponding slot (Drawing 1.2), this will help keep the joint aligned, repeat this process for all four corners, see drawing 1.0.

*\*Fine adjustment of the joint can be achieved using a hand held T25 driver*

- Now the eaves beam is fully jointed it can be carefully positioned centrally on the upstand, see drawing 1.1. The outermost leg should be in line of the external face of the upstand, see drawing 1.2.

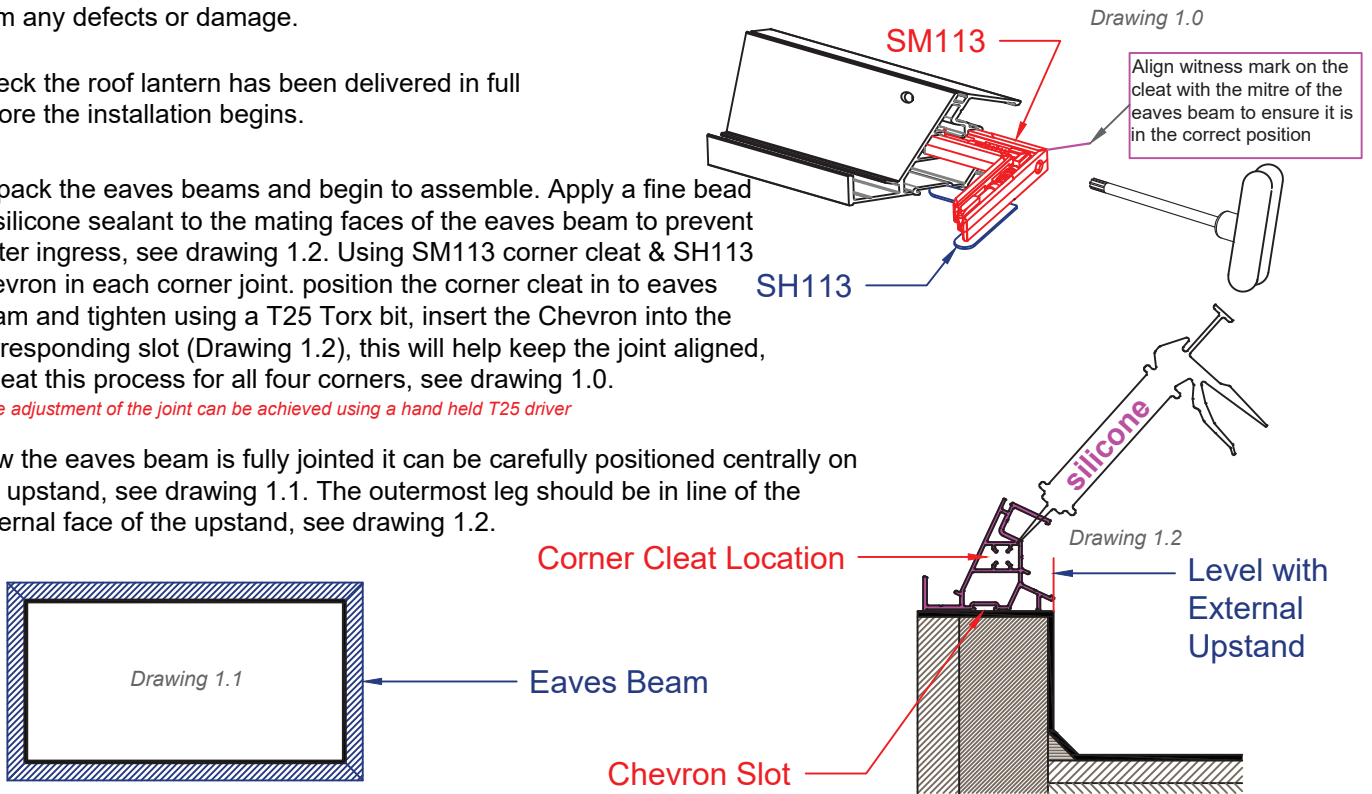

- Unpack the ridge, along with the roof bars. Now the rafters can be fitted to the ridge. All Rafter to Ridge Connector mouldings will be pre-fitted to the ridge body. Slide the rafter onto the correct moulding and fasten using two SRH111 fixings screws (4.8x32mm pan head) through the pre-drilled holes in the ridge body, see the drawings below.

**ALWAYS SUPPORT THE RIDGE WHILE ATTACHING BARS. THE ROOF IS NOT DESIGNED TO BE SELF SUPPORTING BEFORE BEING ATTACHED TO THE EAVES BEAM - THIS WILL LIKELY LEAD TO BROKEN CROWN MOULDINGS.**

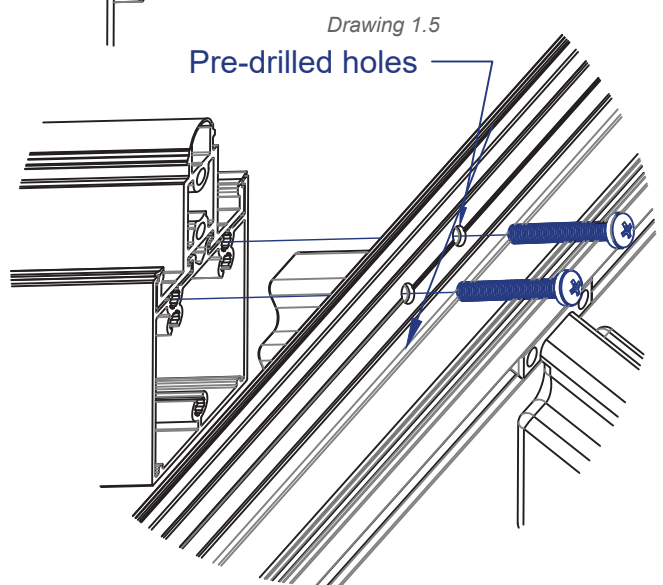
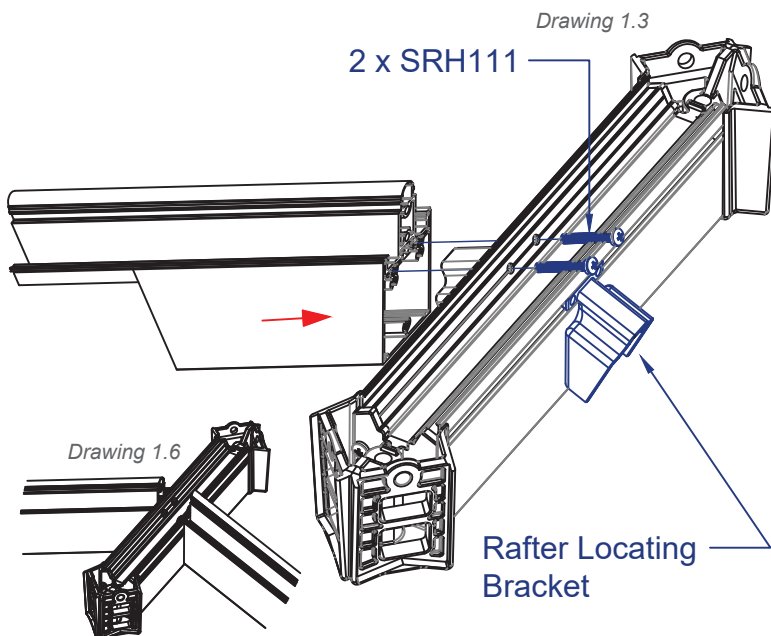
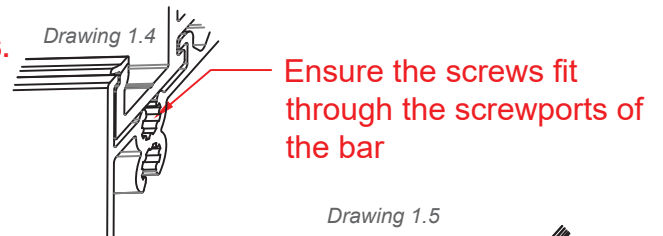

- Once all ridge rafters are fully fitted to the ridge body, the ridge assembly can be carefully lowered on to the Eaves Beam. If your roof lantern does not have ridge rafters, fit the hip bars, see drawing 2.0.

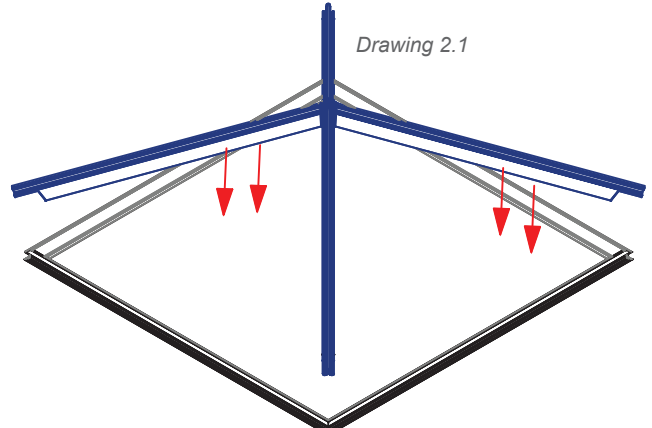
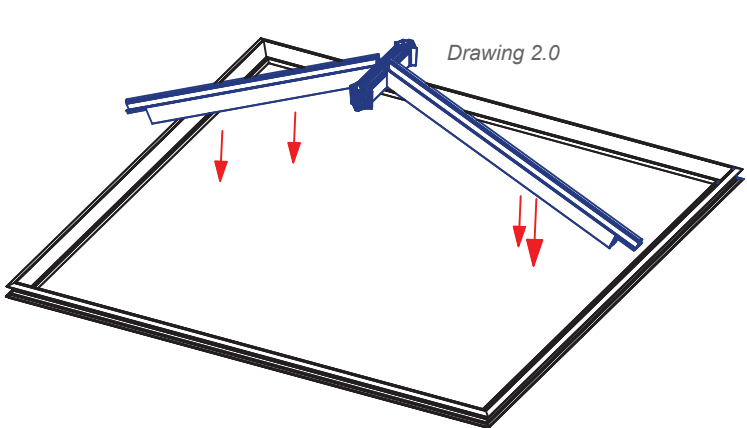

**ALWAYS SUPPORT THE RIDGE WHILE ATTACHING BARS. THE ROOF IS NOT DESIGNED TO BE SELF SUPPORTING BEFORE BEING ATTACHED TO THE EAVES BEAM - THIS WILL LIKELY LEAD TO BROKEN CROWN MOULDINGS.**

- Locate the hip & central rafters by hooking the bracket through the cavity of the crown moulding, this will temporarily hold the bars in place until the primary fixing screw is fastened. Using SRH114 (M8x50 Screw) & SRH124 (M8 Washers) fix through the screw port of the hip & central rafter, taking care not to over tighten the screws. See drawings below.

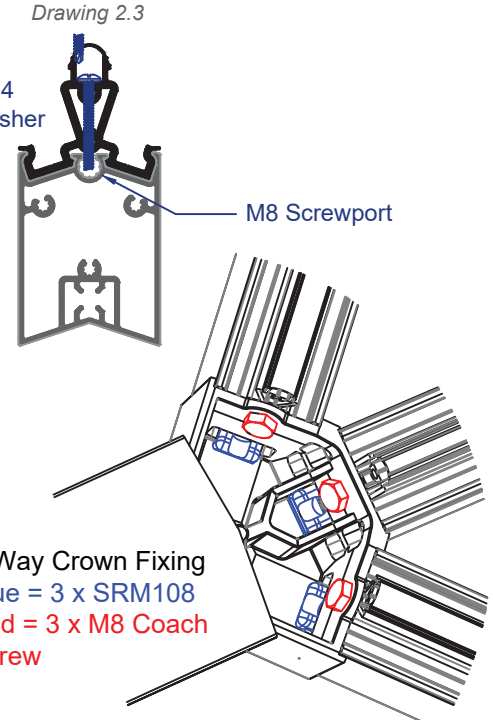
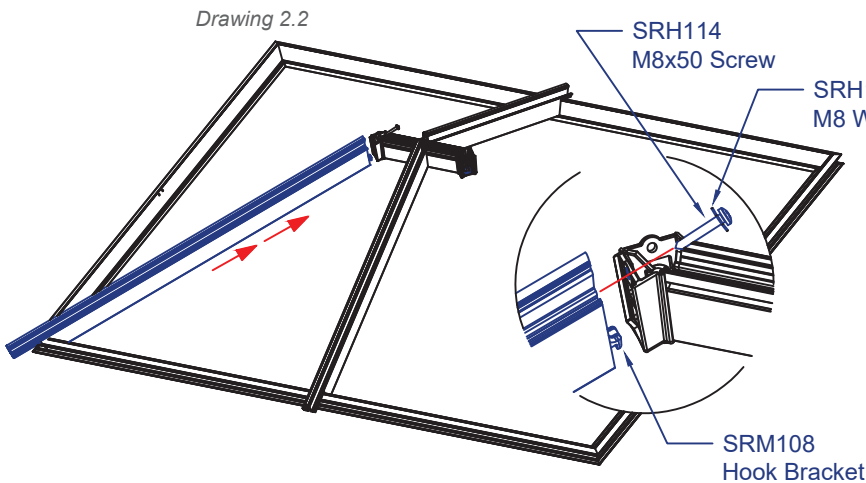

- If the roof you are installing does not have a ridge body, attach the hips to the 4-way crown moulding in the same manner as above, please ensure to use the M8 washers provided.

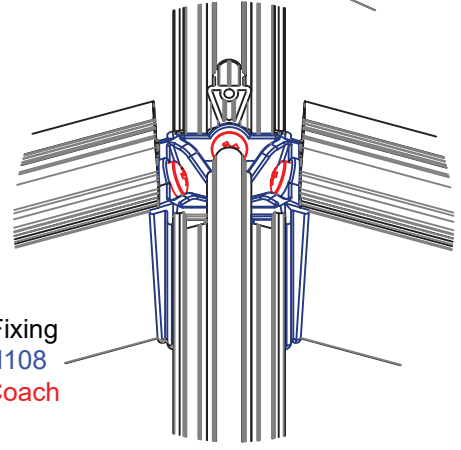

To gain easier access to the M8 fixing Screws you can loosen the screws that fasten the hip body to the aluminium box section underneath and slide down the hip rafters See drawing 2.3.

Once all M8 screws are fastened through the moulding (taking care not to over tighten the fixings). Now slide the hips back into their correct position and re-tighten the 2 fixing screws that prevent hip slippage.

- Fit the Ridge glazing channel to the ridge body by centralising the channel and secure with the SRH117 fixings through the pre-drilled holes, see drawing 2.3.

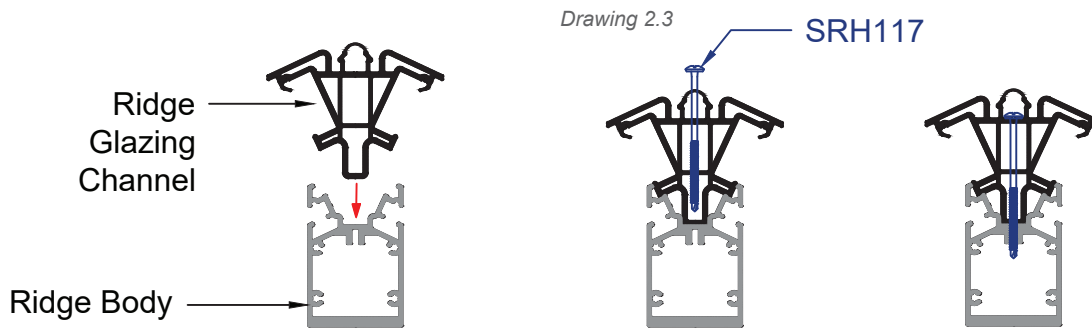

- Using SRH111 (4.8x32 pan head) screws you can begin to attach all rafters to the eaves beam through the pre-drilled holes ensuring the screws pick up on the screw ports within the rafter bar (2 fixings per rafter). Repeat this process until all bars are fully fasten to the eaves beam, see the drawings below.

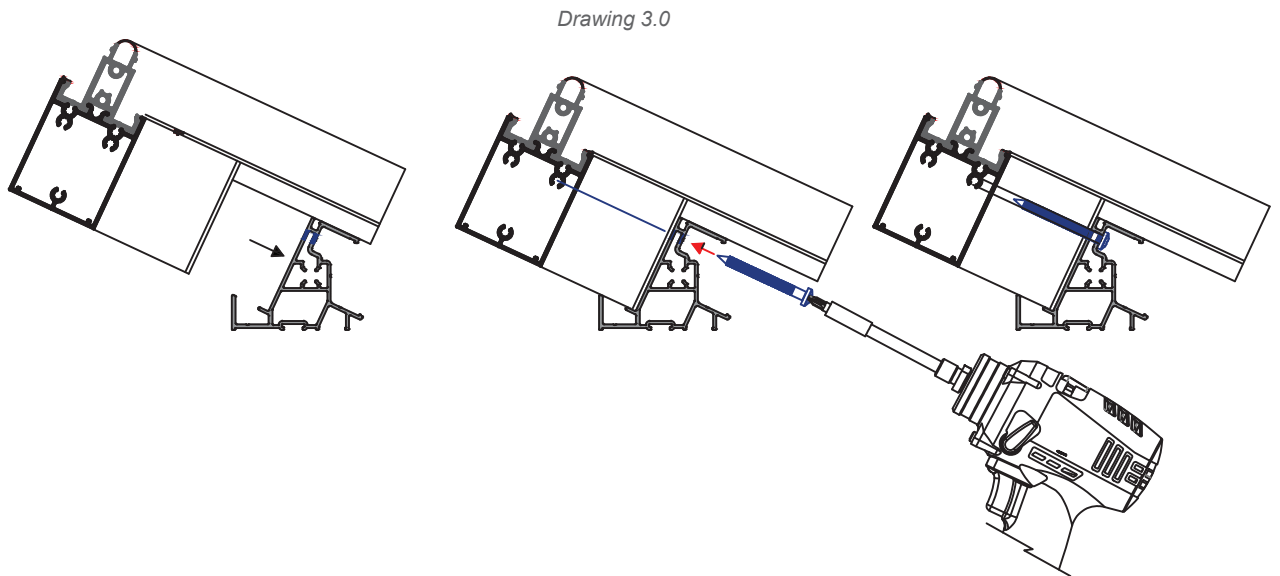

- SRH112 (4.8x50 pan head) screws & SRM103 (Eaves Beam Corner Connector) are used to secure the hip rafters to the eaves beam through the pre-drilled holes in the eaves beam. Repeat this process until all bars are fully fasten to the eaves beam, again, ensuring all fixings fasten through the hip rafter screw ports. See drawings below.

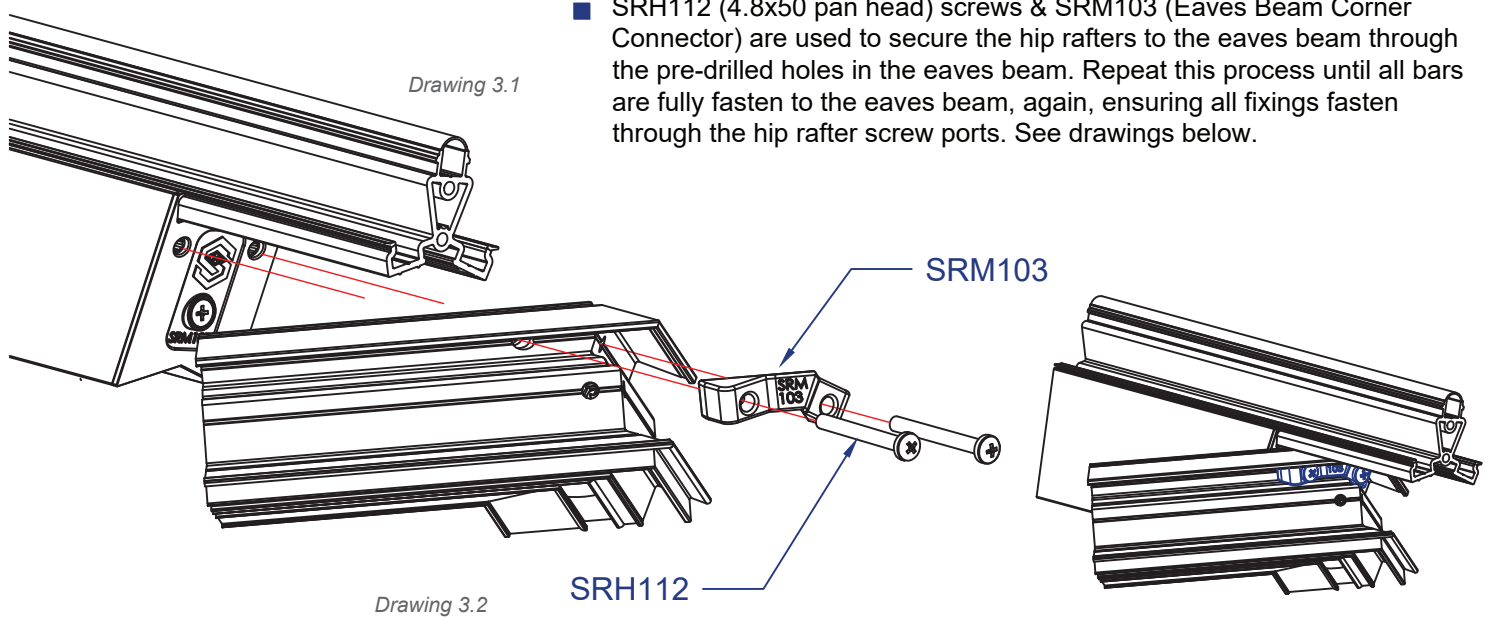

- Jack Rafters - If the roof has jack rafters, please follow the steps below;

Slide SRM104 jack rafter bracket into the jack rafter. Now offer the jack rafter to the hip bar, the bracket will fit within the channel of the hip bar, once the jack rafter is sitting perpendicular to the eaves beam and is fitted tight up against the hip rafter, it can now be fixed in to position. Using 2xSRH112 & 2 x SRMH116. Please note, these holes are not pre-drilled, this is to allow for fine adjustment on site to create a tight joint between the hip & jack rafter, see drawings below.

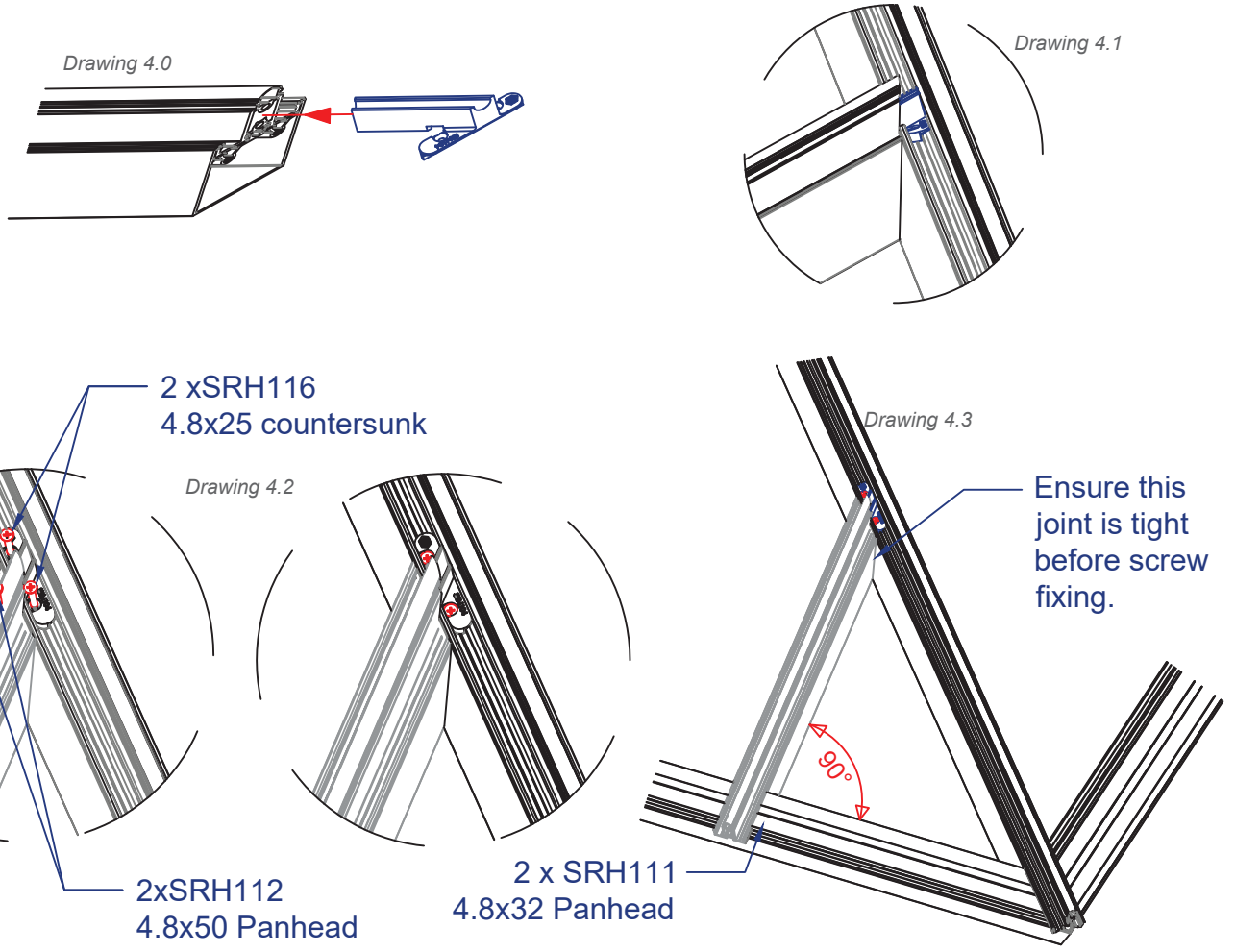

- Once all the roof bars have been fully fastened to the eaves beam & ridge, you can fasten the roof to the timber upstand, using SRH113 (5.5x70mm) fixings through the pre-drilled holes in the eaves beam. Ensuring the outermost leg of the eaves beam is flush with external upstand. see drawings below.

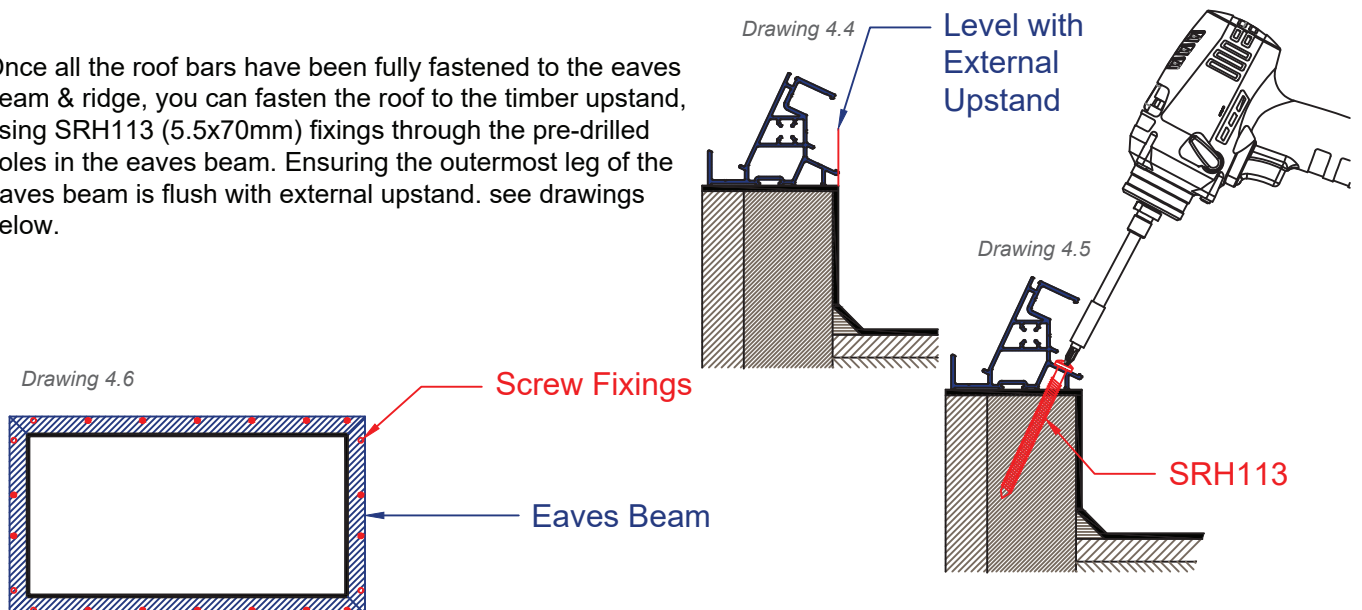

**All fixings should now be fully secured, check that the ridge is level, if adjustments are needed, loosen the fixings to make the necessary adjustments and re tighten all fixings.**

- Now Silicone Seal the perimeter of the eaves beam before the eaves beam body is fitted, Fill the channel of the eaves beam with suitable silicone sealant as per the drawing below, 4.7 & 4.8.

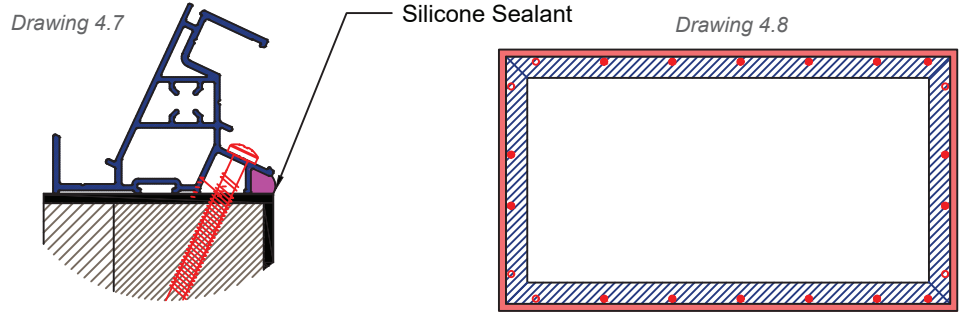

- Begin to attach the fascia trim, using a nylon hammer this can be carefully tapped in to position, you will hear a click when fully seated. This component has a full length gasket that seals the roof against the timber upstand, see the drawing 5.0.

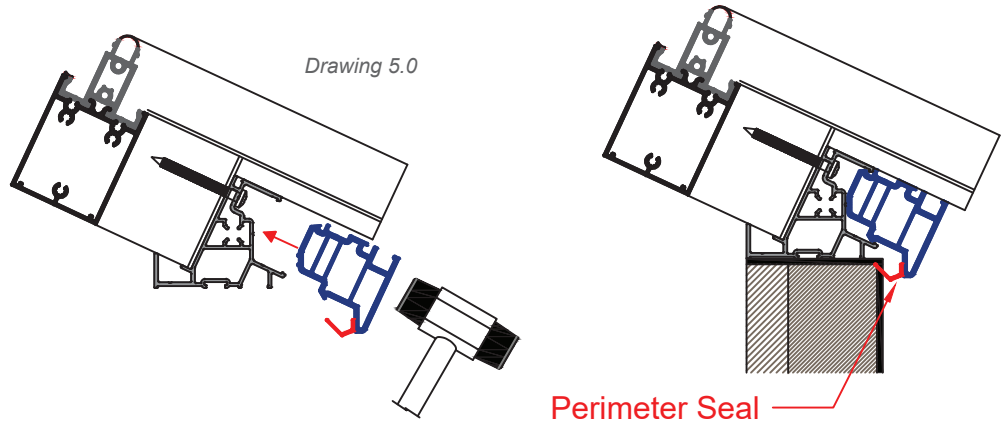

- Now the glass infill trims can be fitted in between all roof bars, this fills the gap between the roof bars and gives a surface for the glass to seal against, see drawing 5.1 & 5.2.

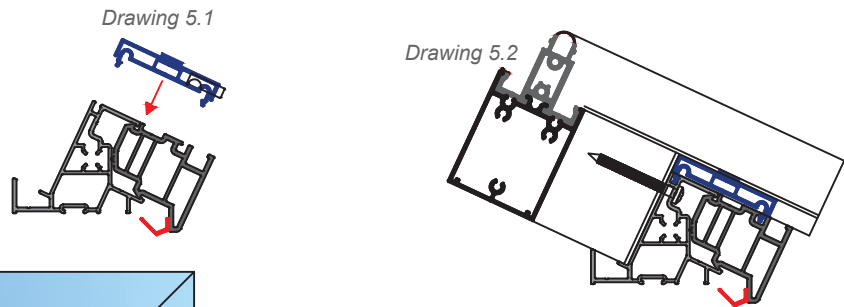

- It's important to follow the correct glazing sequence to equally load the roof during installation, see drawing 5.7.

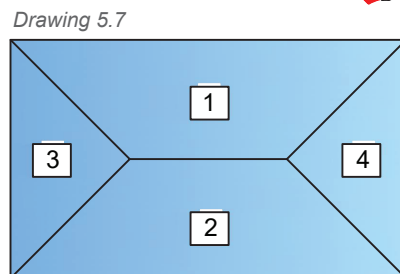

## Glazing Order

- Fit the correct glass end closure on to the corresponding glass unit, ensuring you position this centrally, leaving an equal gap either end, see drawing 5.3.

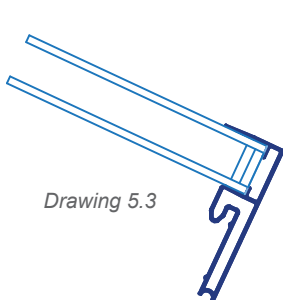

- Now centralise the unit within the glazing bar so there is equal cover on either side and lower the glass unit in to position. The hook detail will locate in to the pocket of the fascia, See drawing 5.4.

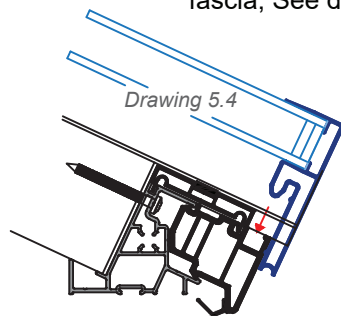

- If the gaps looks correct, raise the unit so the backing taped can be removed from the tape, then carefully lower the glass unit into position, see drawings 5.5 & 5.6.

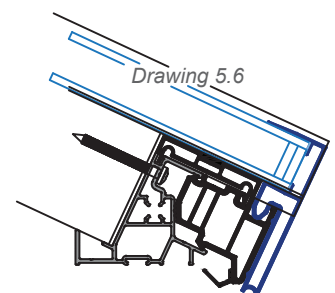
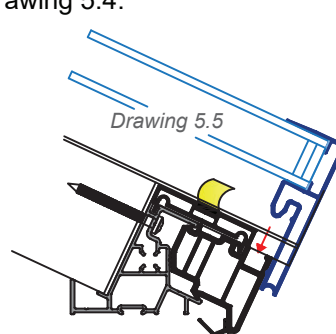

**Secured By Design Specification**

- If the roof lantern you are installing is SBD approved then you must follow steps, 5.7 & 5.8. Other wise skip to the step 6.
- All roof bars have 2 clamping plates fitted at the top & bottom of each bar. If the roof has jack rafters a third bracket will be fitted the the hip rafters only, the location for these brackets have been prepped by the fabricator to ensure the clamping plate can be positioned correctly.
- There are 2 types of clamping plates, hip bars use the angled clamping plate SRH129 (Red) & rafters use the flat clamping plates SRH128 (Blue), as per the drawings below.
- All clamping plates will need to be fitted to ensure the roof lantern is SBD compliant. Using 3 x SRH130 50mm anti tamper stainless steel security screws, carefully attach the clamping plate to the roof bar through the predrilled holes.

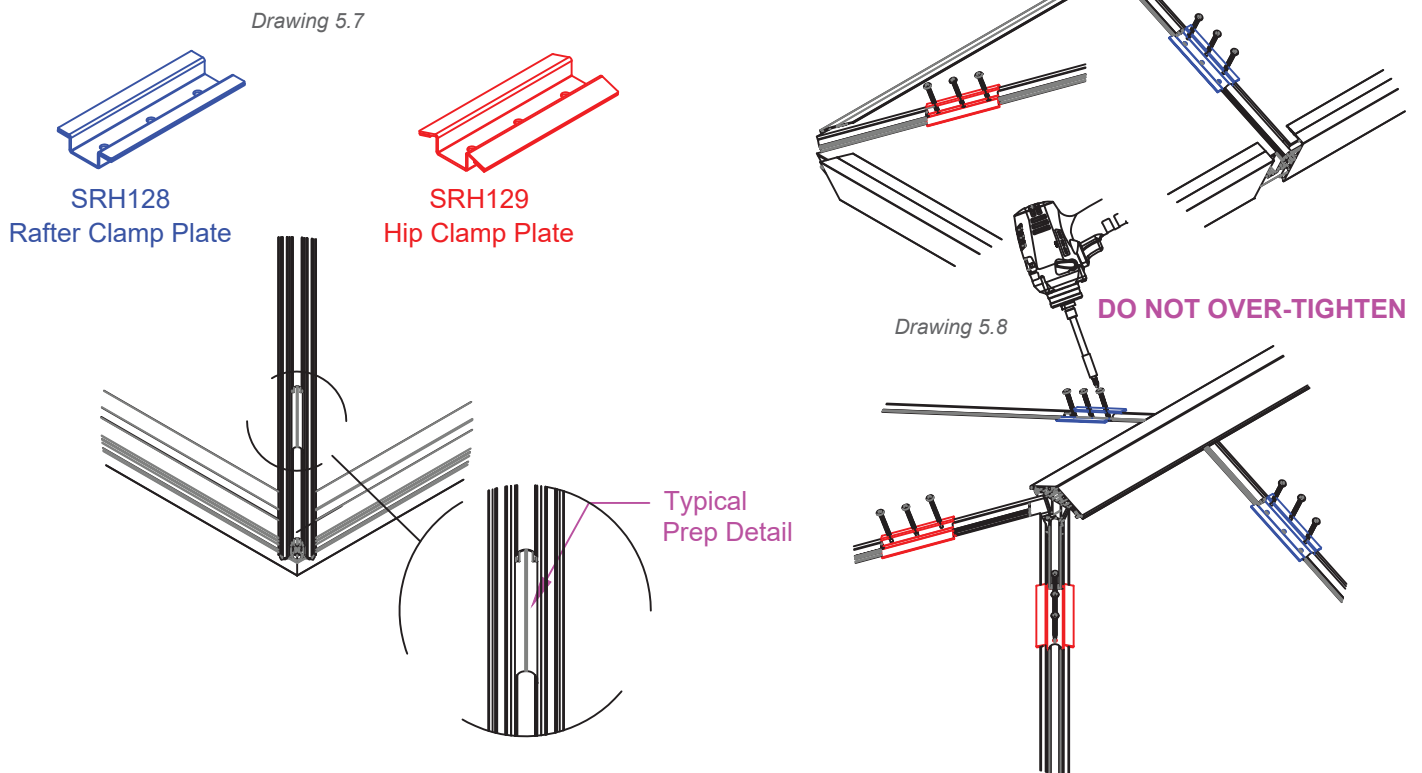

- Top caps are clipped on to their respectively numbered glazing bar. Tap down until fully located using a nylon or rubber mallet on a piece of timber to avoid causing damage to the top caps, See drawing 6.0.

Ensure all caps are flush at the bottom of each bar.

**\*Jack Rafter Top Caps require a selant joint where they meet the hip rafter top cap to prevent water ingress.**

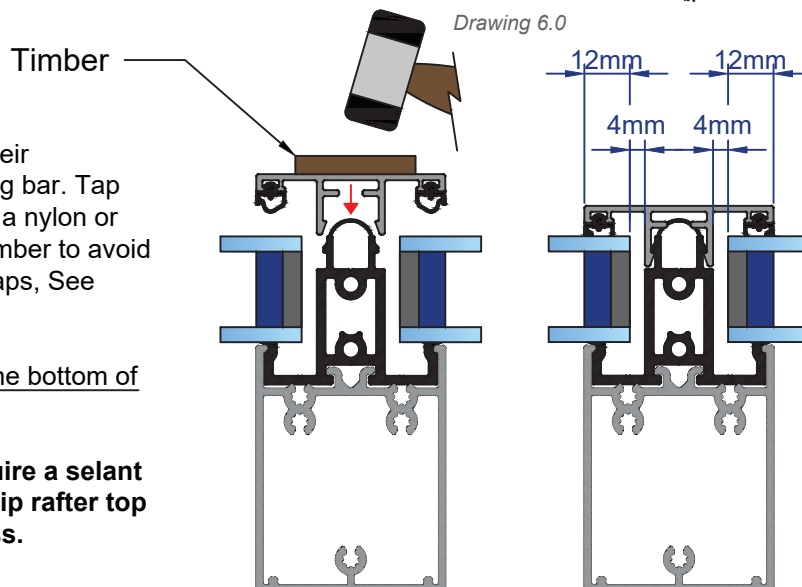

- Now fit the end caps to all bars using 4.8mm Security screws (Driver Bit Provided SRH118) each cap requires 2 screws, see drawing 6.1.

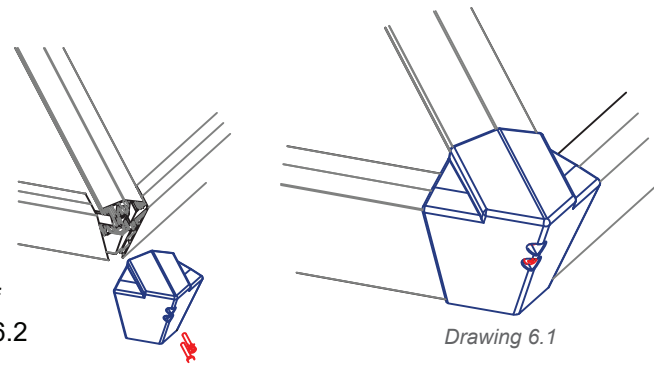

Drawing 6.1

- Before fitting the Crown Top Cap, first apply a generous bead of silicone sealant to seal the top caps & ridge body, see drawing 6.2 ensuring the gaskets in the top caps are sitting tight together.

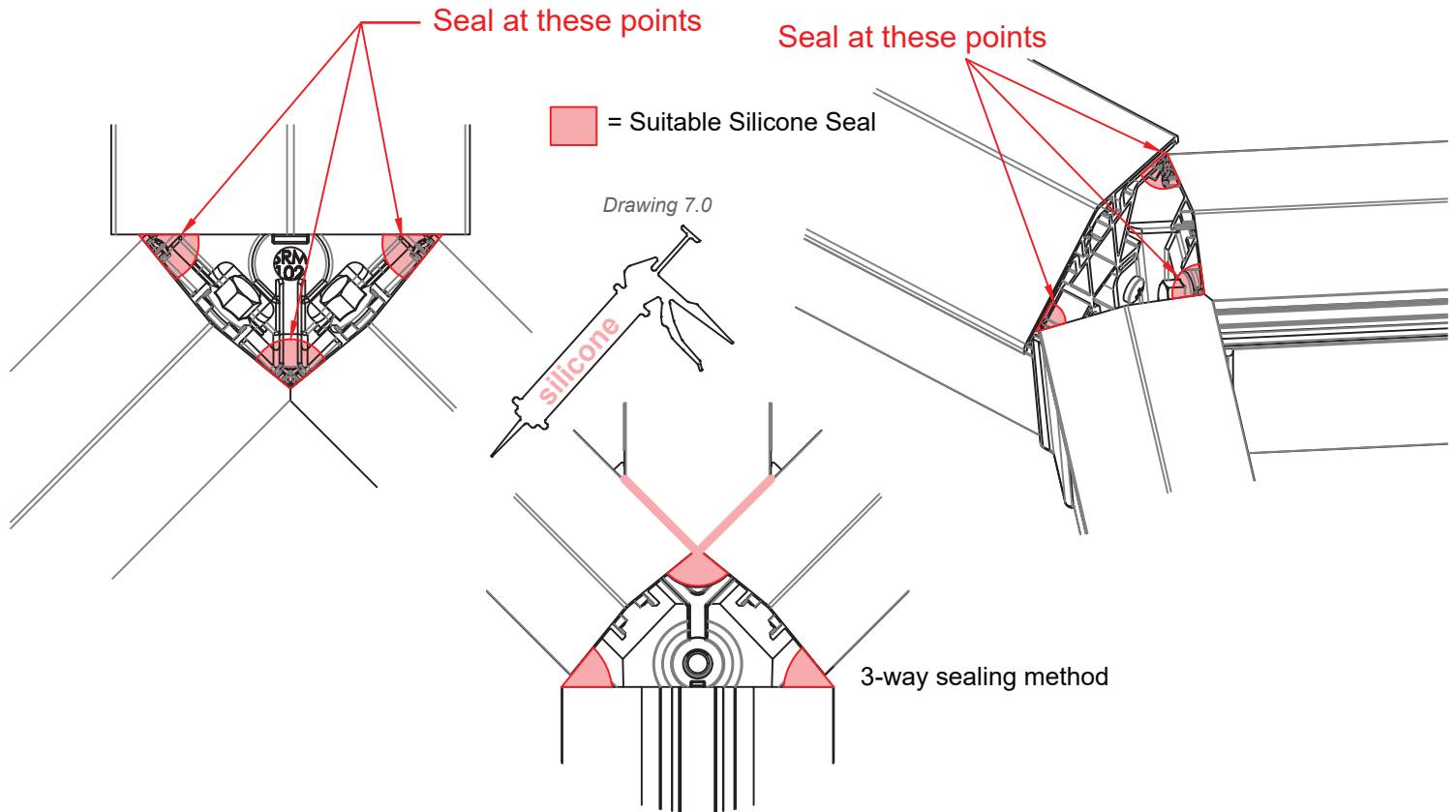

Drawing 7.0

3-way sealing method

- Ensure the Crown Top Cap Seals are in place and seated correctly, then place the top cap onto the roof in it's correct position.

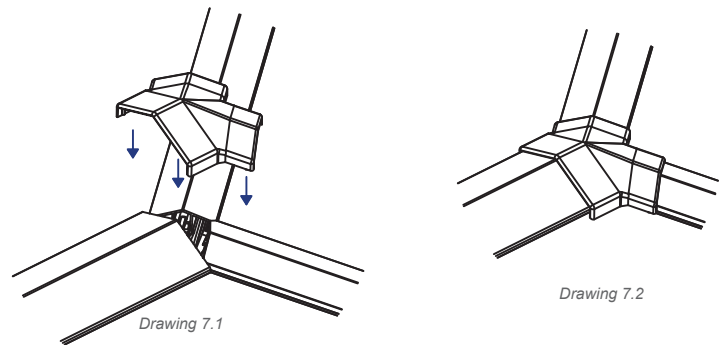

Drawing 7.1

Drawing 7.2

- Using SRH110 (M8x110 cap head) fasten through the crown moulding from the underside of the roof, do not over-tighten this fixing. This will compress the Crown Top Cap Seals and form a seal between the top caps, see drawing 7.1.

- Now Fit SRM102 (screw cover cap) to conceal the fixing using a small amount of silicone sealant to ensure this cover will not fall off in conditions of extreme temperatures, see drawing 7.2.

